



PROFESSIONAL AUGER SERIES

MODELS

- 615 Hex, 615 Round
- 1025 Hex, 1025 Round
- 1530 Hex, 1530 Round
- 2035 Hex, 2035 Round

Owner: _____

Date Purchased: _____

Model #: _____ Serial #: _____

Manual #: 9MPRO2457080

⚠ DANGER

Si no entiende ingles, se prefiere que busque a alguien que interprete las instrucciones para usted.

Operator's Manual

Danuser LLC
 500 E. 3rd St.
 P.O. Box 368
 Fulton, MO 65251
 Tel: (573) 642-2246 Fax: (573) 642-2240
 E-mail: sales@danuser.com
 Website: www.danuser.com



Dear Owner/Operator,

Thank you for purchasing this Danuser Hydraulic Earth Auger. We appreciate your business.

Your safety as an operator of our product is very important to us. Therefore, *before* you assemble, install, operate, or maintain your Danuser Earth Auger, read and understand this manual thoroughly. If there is anything you do not understand, immediately contact your dealer, or contact our factory direct.

Tel:	(573) 642-2246
Fax:	(573) 642-2240
E-mail:	sales@danuser.com

Your satisfaction in the performance and longevity of our product is also very important to us and can be prolonged by proper assembly, installation, operation, and maintenance as instructed in this manual.

Thank you again for your business and for your trust in our product. Please feel free to contact us at any time for further assistance.

Sincerely,

Danuser LLC

500 E. 3rd St., P.O. Box 368, Fulton, MO 65251
Tel: (573) 642-2246 Fax: (573) 642-2240
E-mail: sales@danuser.com Website: www.danuser.com

Foreword

Please read this manual thoroughly!

Before you assemble, install, operate, or maintain your Danuser Earth Auger, read this manual thoroughly. If there is anything you do not understand, immediately contact your dealer, or call our factory direct at (573) 642-2246. Powered equipment can be dangerous if not assembled, installed, operated, or maintained properly.

Warranty Registration

To activate your warranty coverage and to provide you with efficient customer service, please fill out your WARRANTY REGISTRATION FORM. This form is included in your unit's paperwork package. If you did not complete a WARRANTY REGISTRATION FORM or did not receive one, please call Danuser LLC. Or, register online at www.danuser.com. Your satisfaction with our product and your safety as a user of our product are both very important to us.

Symbols

 This SAFETY ALERT symbol identifies important safety messages. Carefully read each safety message that follows. Failure to understand and obey a safety message, or recognize a safety hazard, could result in injury or death to you or others around you. The operator is ultimately responsible for the safety of himself, as well as others, in the operating area of the earth auger.





<i>Symbol</i>	<i>Meaning</i>
	This is important information for proper use of this equipment. Failure to comply may lead to premature equipment failure.
	Failure to follow these instructions may cause damage to the implement or the vehicle, or minor personal injury.
	Failure to follow these instructions may result in personal injury or death.
	Immediate hazard! Failure to understand and obey this warning is likely to result in personal injury or death.

Table of Contents

	Page
Letter to the Owner/Operator	2
Foreword	3
Symbols	3
Safety	4
Drive Unit Specifications	6
Hydraulic Requirements	7
Assembly & Installation	8
Operation	15
Troubleshooting	17
Maintenance	18
Drive Unit Parts	19
Decals & Safety Signs	20
Augers & Accessories	22
Warranty	Form No. 3219

DANGER

Improper operation of this earth auger can cause serious personal injury or death. Operation of this earth auger should only be done by a competent adult acting in compliance with the Operator's Manual. Since drilling operations are beyond our control, we disclaim all liability for any damages, injuries, or death which may result.

WARNING

Working with unfamiliar equipment can lead to careless injuries. Read and understand this manual and the manual for your vehicle before assembling, installing, operating, or maintaining this earth auger. If there is anything in this manual you do not understand, contact your dealer or Danuser LLC. The safe use of this machine is strictly up to you, the operator. If this unit is used, loaned, or rented by any other person, it is the owner's responsibility to make certain that the operator prior to operating:

- Reads and understands the Operator's Manuals
- Is instructed in safe and proper use

There is an entanglement risk if you replace the **special** auger retaining bolt with a bolt longer than specified by Danuser LLC. This improper replacement occurs most often on machines that are loaned or rented to someone who has not read the Operator's Manual and is not familiar with an earth auger.

- This earth auger is designed for one-man operation from the vehicle seat. It is the responsibility of the operator to see that no one is within twenty-five feet (25') of the earth auger when it is started or in use. Do not operate the earth auger with another person near or in contact with any part of the drive unit or auger. Serious personal injury or death may result if any attempt is made to assist drilling operation by hand.
- All operators of this equipment must read and understand this entire manual, paying particular attention to safety messages and operation instructions, prior to assembling, installing, or operating the earth auger.
- Please remember it is also important that you read, understand, and follow the safety signs on the earth auger. Clean or replace all safety signs if they cannot be clearly read and understood. They are there for your safety as well as the safety of others. Danuser LLC will furnish new safety signs upon request at no charge.
- All things with moving parts are potentially hazardous. There is no substitute for a cautious, safe-minded operator who recognizes potential hazards and follows reasonable safety practices.
- Personal protection equipment including hard hat, safety glasses, safety shoes, and gloves are recommended during assembly, installation, operation, maintenance, removal, or movement of the earth auger.
- When the use of hand tools is required to perform any part of assembly, installation, maintenance, removal, or movement of the earth auger, be sure the tools used are designed and recommended by the tool manufacturer for that specific task.
- Never check pressurized system for leaks with your bare hand. Wear proper hand and eye protection and use wood or cardboard when searching for suspected leaks. Oil escaping from pinhole leaks under pressure can penetrate skin and create a serious medical emergency. If any fluid is injected into the skin, gangrene, blood poisoning, even death may result. Obtain medical attention immediately.
- Always use two people to handle heavy, unwieldy components during assembly, installation, maintenance, removal, or movement of the earth auger.
- Never place any part of your body where it would be in danger if movement should occur during assembly, installation, operation, maintenance, removal, or movement of the earth auger.
- Check clearances between vehicle and auger, as well as operator and auger, across the full range of loader arms' operating heights. Keep earth auger in cradle when not drilling.
- Only properly trained people should operate this equipment. Do not allow anyone who has not read this entire manual and understood the safety rules, safety signs, and operation instructions to use this earth auger.
- Never allow children to operate or be around this earth auger.

Safety

(continued)

- Do not allow riders on the equipment at any time. There is no safe place for any riders.
- Never use alcoholic beverages or drugs which can hinder alertness or coordination while operating this equipment. Consult your doctor about operating this machine while taking prescription medications.
- Consult local utility companies to make certain there are no buried gas lines, electrical cables, etc., in the work area before beginning operation.
- Before beginning operation, clear the work area of objects which might be picked up and thrown by or entangled in the auger.
- Before you operate the earth auger, check over all pins, bolts, and connections to be sure all are securely in place. Replace any damaged or worn parts immediately.
- Never replace the auger retaining bolt with anything other than the specified length bolt in this manual. A longer, or protruding, fastener is more likely to grab clothing or gloves, which can result in serious injury or death.
- Keep hands, feet, hair, jewelry, and clothing away from all moving and/or rotating parts.
- Never place yourself between the vehicle and the earth auger while the vehicle is running.
- Worn teeth or a slightly rounded point can seriously affect auger penetration. Check for wear before each use, and replace as necessary.
- Never position the auger point by hand or with any tool when the vehicle is running.
- Never position the auger point by putting your hands on the auger or drive unit.
- Do not shovel dirt away from a rotating auger, as the shovel can be caught and thrown by the auger.
- Never transport with the drive unit out of the cradle or while the auger is rotating.
- Do not walk or work under a raised earth auger unless it is securely blocked or held in position. Do not depend on the vehicle hydraulic system to hold the earth auger in place.
- A heavy load can cause instability of the vehicle. Use extreme care during travel. Slow down on turns and watch out for bumps. Use all safety devices, including a seat belt, as recommended in the vehicle operator's manual.
- Do not operate the earth auger on steep hillsides. When drilling on uneven or hilly terrain, position the vehicle with the earth auger uphill. With the earth auger downhill, the vehicle could tip when attempting to raise the auger from its hole. Consult your vehicle operator's manual for maximum incline allowable.
- Always shut off the vehicle engine and remove the key before dismounting the vehicle. Never leave equipment unattended with the vehicle running.
- Before disconnecting hydraulic lines or fittings be sure to relieve all pressure by cycling all hydraulic controls after shutdown. Remember hydraulic systems are under pressure whenever the engine is running and may hold pressure after shutdown.
- Most accidents occur because of neglect or carelessness. Keep all helpers and bystanders twenty-five feet (25') away from an operating earth auger.
- Always use care when operating an earth auger.

Safety is a primary concern in the design, manufacture, sale, and use of earth augers. As the manufacturer of your earth auger, we want to confirm to you, our customer, our concern for safety.

Drive Unit Specifications

	615	1025	1530	2035
Minimum Hydraulic Flow	6 GPM	10 GPM	15 GPM	20 GPM
Maximum Hydraulic Flow	15 GPM	25 GPM	30 GPM	35 GPM
Maximum Continuous Operating PSI	3000 PSI	3000 PSI	3000 PSI	3000 PSI
Maximum Auger Diameter	24 inches	30 inches	36 inches	36 inches
Output Spindle	2" Hex or 2-9/16" Rd.	2" Hex or 2-9/16" Rd.	2" Hex or 2-9/16" Rd.	2" Hex or 2-9/16" Rd.

Model 615

GPM	RPM
6	33
8	44
10	55
12	66
15	82

PSI	TORQUE
2000	1115 Ft.-Lbs.
2500	1393 Ft.-Lbs.
3000	1672 Ft.-Lbs.

Model 1025

GPM	RPM
10	39
14	55
18	70
20	78
25	98

PSI	TORQUE
2000	1569 Ft.-Lbs.
2500	1962 Ft.-Lbs.
3000	2354 Ft.-Lbs.

Model 1530

GPM	RPM
15	45
20	60
25	75
30	90

PSI	TORQUE
2000	2045 Ft.-Lbs.
2500	2557 Ft.-Lbs.
3000	3068 Ft.-Lbs.

Model 2035

GPM	RPM
20	47
25	59
30	71
35	82

PSI	TORQUE
2000	2605 Ft.-Lbs.
2500	3256 Ft.-Lbs.
3000	3907 Ft.-Lbs.

Torque and output speed specifications are based on theoretical values and are provided for comparative purposes only.

Hydraulic Requirements

Filtration Requirements:

- A filter of, at least, 25 micron filtration is required. A filter capable of 10 micron filtration is preferred. The majority of paper type filters are 25 microns or better.

NOTE

The life of the hydraulic motor is almost entirely dependent upon cleanliness of the oil. Instructions in your vehicle operator's manual regarding filter and oil changes should be carefully followed. Even small amounts of dirt in the hydraulic oil can cause premature motor failure that is not covered by warranty.

- A low pressure type filter can be installed in the return line from the control valves to the sump. A low pressure type filter can, also, be installed in the sump or pump intake line, but must be sized large enough to avoid starving the pump.
- A high pressure type filter can be used between the pump and the control valves.
- If the source of the hydraulic power does not have a filter, it will be necessary to install one at some point in the system so, at least, part of the hydraulic oil is being filtered whenever the system is operating. After a filter is installed and before attaching the drive unit, the entire hydraulic system should be drained, filled with new oil, and operated for 30 minutes or until the system is warm. During this run time, operate all valves, cylinders, and hydraulic motors on the machine.

Pressure and Flow Requirements:

- Models 615, 1025, 1530, and 2035 Danuser Earth Augers are designed to operate within the pressure range of 1500 to 3000 PSI.
- Operating flow rate is dependent on model: 6 to 15 GPM for Model 615, 10 to 25 GPM for Model 1025, 15 to 30 GPM for Model 1530, and 20 to 35 GPM for Model 2035.

Valve Requirements:

- The hydraulic system used to power the drive unit should be equipped with a four-way valve large enough to carry full pump outlet without restricting flow and causing oil heating.
- The four-way valve requires a relief valve which will open and relieve extreme pressures between the drive unit and control valve, even when the control valve is in a neutral position. This feature can be obtained by connecting two external relief valves between the main lines running from the control valve to the drive unit in such a way that high pressure in either line will be relieved to the other line.

Hydraulic Hose Requirements:

- High pressure hoses of, at least, 1/2 inch inside diameter connect four-way valve to the hydraulic fittings on the top of the drive unit. If the drive unit is mounted 10 feet or more from the hydraulic outlets on your unit, or the pump delivers 20 GPM or more, hose size should be increased to 3/4 inch inside diameter.
- Working pressure of hydraulic hoses must be higher than the rated vehicle hydraulic pressure.
- An abrasion sleeve is recommended on all hydraulic hoses.
- The hydraulic hoses should be equipped with a 45-degree fitting on the drive unit end.
- The hydraulic fittings on the top of the drive unit are #10 JIC male.
- Since the motor is reversible, hose connections to motor fittings are interchangeable.
- All hoses, pipes, and fittings used to connect the drive unit should be thoroughly cleaned before use. Care should be taken to see that no thread sealer or metal chips are forced to the inside of the joints when connections are being tightened.

Hydraulic Fluid Selection Requirements:

- Premium grade petroleum based fluids will provide the best performance.
- A hydraulic fluid that contains anti-wear agents, rust inhibitors, anti-foaming agents, and oxidation inhibitors is recommended.
- The viscosity of the fluid should never fall below 70 SUS (13 cST). The best viscosity range of the drive unit is 100-200 SUS (20-43 cST).

Assembly & Installation

Skid-Steer Mount

Drive unit and auger exploded views and part lists are detailed on separate pages in this manual.

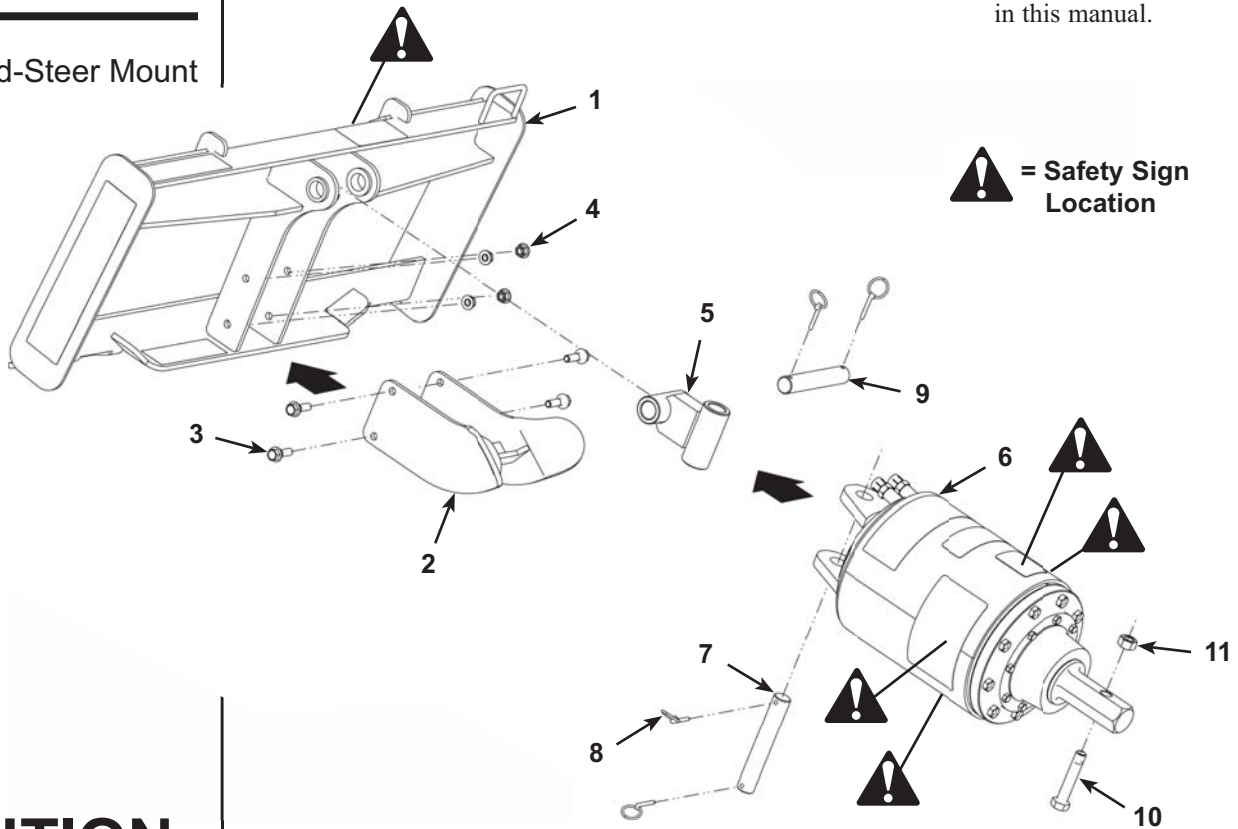

= Safety Sign Location

CAUTION

Because of the weight of some components, and because some components are difficult to balance, two people are required for safe assembly and installation of this equipment.

WARNING

Personal protection equipment including hard hat, safety glasses, safety shoes, and gloves are recommended during assembly, installation, operation, maintenance, removal, or movement of the earth auger. Do not allow long hair, loose fitting clothing, or jewelry to be around moving parts.

REF. NO.	PART NO.	DESCRIPTION	QTY.
1	10499	Quick Attach Plate Assembly (incl. REF. NOS. 1-5, two pcs. of 8, and 9)	1
2	10965	Cradle Assembly	1
3	10975	Bolt (1/2"-13 x 1-3/4")	4
4	6196	Nut (1/2"-13)	4
5	10022	Knuckle Assembly	1
6	----	Drive Unit	1
7	10032	Pin (1-1/4" x 7-5/8")	1
8	1600	Klik Pin	4
9	9598	Pin (1-1/4" x 7-1/8")	1
10	10038	Special Retaining Bolt - 2" Hex (3/4"-10 x 4", Gr. 8, 3/4" of thread)	1
	10039	Special Retaining Bolt - 2-9/16" Rd. (7/8"-9 x 4-1/4", Gr. 8, 3/4" of thread)	
11	10041	Nut (3/4"-10) - 2" Hex	1
	10042	Nut (7/8"-9) - 2-9/16" Rd.	

- STEP 1: Bolt cradle assembly (2) to quick attach plate assembly (1) using bolts (3), and secure with nuts (4). Nuts (4) must be torqued to 115 ft.-lbs.
- STEP 2: After removing bucket or other attachment from vehicle, secure quick attach plate assembly (1) to vehicle per vehicle manufacturer's recommendations.
- STEP 3: Attach knuckle assembly (5) to the drive unit (6) using pin (7). Secure pin (7) with klik pins (8).
- STEP 4: Attach knuckle assembly/drive unit to the quick attach plate assembly (1) using pin (9). Secure pin (9) with klik pins (8).

Assembly & Installation

Offset Skid-Steer Mount

Drive unit and auger exploded views and part lists are detailed on separate pages in this manual.

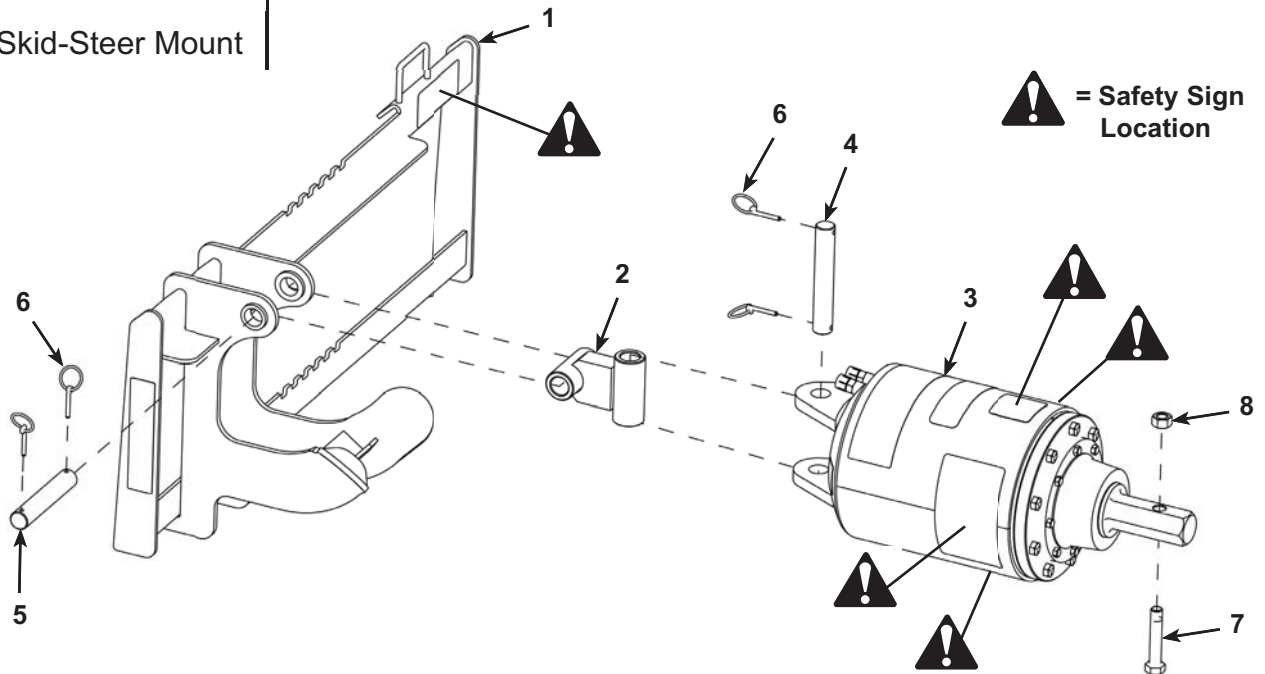

⚠ CAUTION

Because of the weight of some components, and because some components are difficult to balance, two people are required for safe assembly and installation of this equipment.

⚠ WARNING

Personal protection equipment including hard hat, safety glasses, safety shoes, and gloves are recommended during assembly, installation, operation, maintenance, removal, or movement of the earth auger. Do not allow long hair, loose fitting clothing, or jewelry to be around moving parts.

REF. NO.	PART NO.	DESCRIPTION	QTY.
1	20656	Offset Quick Attach Plate Assembly (incl. REF. NOS. 1-2, 5, and two pcs. of 6)	1
2	10022	Knuckle Assembly	1
3	----	Drive Unit	1
4	10032	Pin (1-1/4" x 7-5/8")	1
5	9598	Pin (1-1/4" x 7-1/8")	1
6	1600	Klik Pin	4
7	10038	Special Retaining Bolt - 2" Hex (3/4"-10 x 4", Gr. 8, 3/4" of thread)	1
	10039	Special Retaining Bolt - 2-9/16" Rd. (7/8"-9 x 4-1/4", Gr. 8, 3/4" of thread)	
8	10041	Nut (3/4"-10) - 2" Hex	1
	10042	Nut (7/8"-9) - 2-9/16" Rd.	

STEP 1: After removing bucket or other attachment from vehicle, secure quick attach plate assembly (1) to vehicle per vehicle manufacturer's recommendations.

STEP 2: Attach knuckle assembly (2) to the drive unit (3) using pin (4). Secure pin (4) with klik pins (6).

STEP 3: Attach knuckle assembly/drive unit to the quick attach plate assembly (1) using pin (5). Secure pin (5) with klik pins (6).

STEP 4: Proceed to STEP 5 on page 14.

Assembly & Installation

Offset Euro Mount

Drive unit and auger exploded views and part lists are detailed on separate pages in this manual.

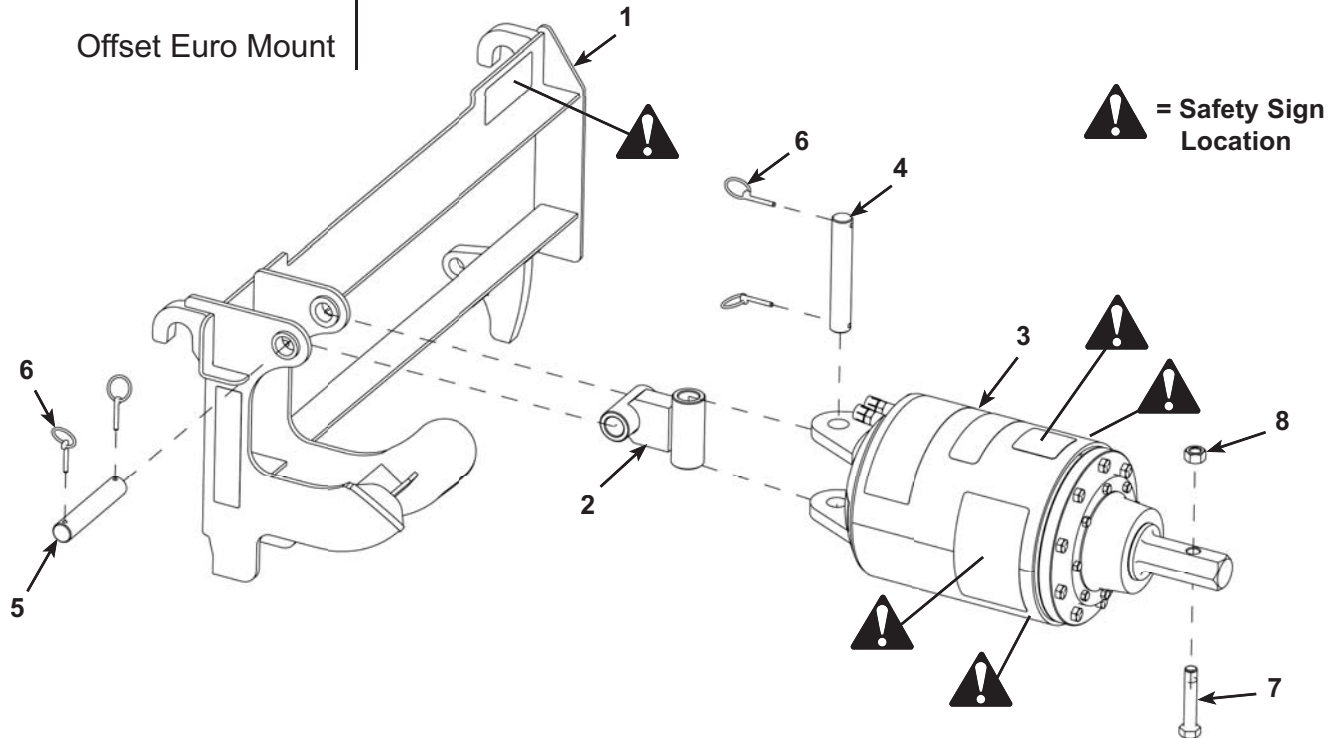

CAUTION

Because of the weight of some components, and because some components are difficult to balance, two people are required for safe assembly and installation of this equipment.

WARNING

Personal protection equipment including hard hat, safety glasses, safety shoes, and gloves are recommended during assembly, installation, operation, maintenance, removal, or movement of the earth auger. Do not allow long hair, loose fitting clothing, or jewelry to be around moving parts.

REF. NO.	PART NO.	DESCRIPTION	QTY.
1	20657	Offset Quick Attach Plate Assembly (incl. REF. NOS. 1-2, 5 two pcs. of 6)	1
2	10022	Knuckle Assembly	1
3	----	Drive Unit	1
4	10032	Pin (1-1/4" x 7-5/8")	1
5	9598	Pin (1-1/4" x 7-1/8")	1
6	1600	Klik Pin	4
7	10038	Special Retaining Bolt - 2" Hex (3/4"-10 x 4", Gr. 8, 3/4" of thread)	1
	10039	Special Retaining Bolt - 2-9/16" Rd. (7/8"-9 x 4-1/4", Gr. 8, 3/4" of thread)	
8	10041	Nut (3/4"-10) - 2" Hex	1
	10042	Nut (7/8"-9) - 2-9/16" Rd.	

STEP 1: After removing bucket or other attachment from vehicle, secure quick attach plate assembly (1) to vehicle per vehicle manufacturer's recommendations.

STEP 2: Attach knuckle assembly (2) to the drive unit (3) using pin (4). Secure pin (4) with klik pins (6).

STEP 3: Attach knuckle assembly/drive unit to the quick attach plate assembly (1) using pin (5). Secure pin (5) with klik pins (6).

Assembly & Installation

Mini-Excavator Mount

Drive unit and auger exploded views and part lists are detailed on separate pages in this manual.

REF. NO.	PART NO.	DESCRIPTION	QTY.
1	----	Drive Unit	1
2	10219	Knuckle Sub-Assembly	1
3	10032	Pin (1-1/4" x 7-5/8")	1
4	1600	Klik Pin	2
5	----	Ear Assembly	2
6	10220	U-Bolt (1/2"-13 x 3-3/4")	4
7	6196	Nut (1/2"-13)	8
8	10038	Special Retaining Bolt - 2" Hex (3/4"-10 x 4", Gr. 8, 3/4" of thread)	1
	10039	Special Retaining Bolt - 2-9/16" Rd. (7/8"-9 x 4-1/4", Gr. 8, 3/4" of thread)	
9	10041	Nut (3/4"-10) - 2" Hex	1
	10042	Nut (7/8"-9) - 2-9/16" Rd.	

CAUTION

Because of the weight of some components, and because some components are difficult to balance, two people are required for safe assembly and installation of this equipment.

WARNING

Personal protection equipment including hard hat, safety glasses, safety shoes, and gloves are recommended during assembly, installation, operation, maintenance, removal, or movement of the earth auger. Do not allow long hair, loose fitting clothing, or jewelry to be around moving parts.

 = Safety Sign Location

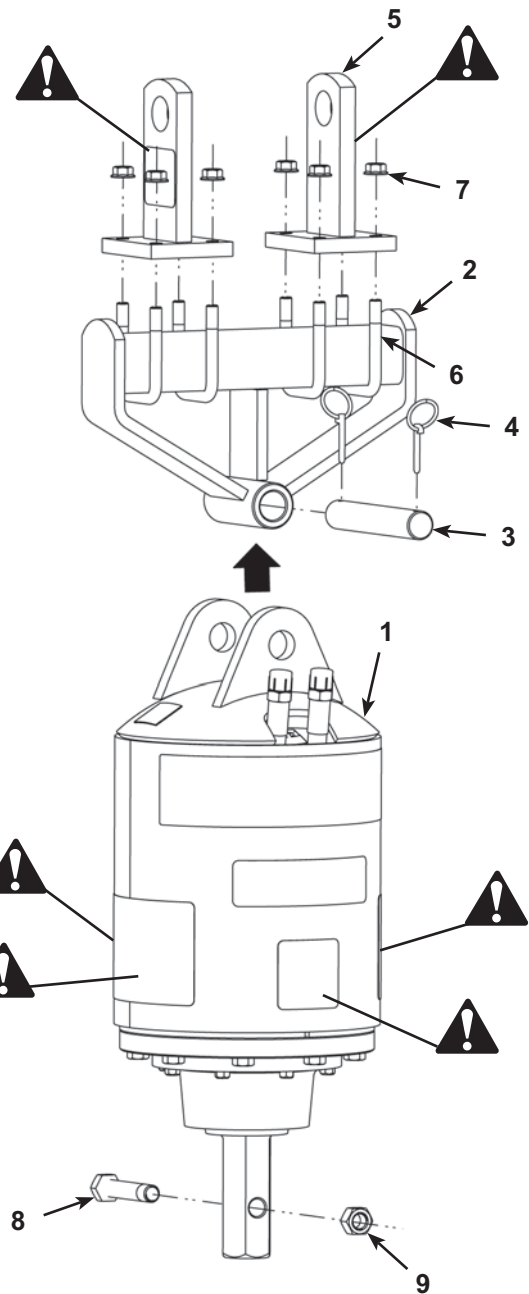

- STEP 1: Attach drive unit (1) to the knuckle sub-assembly (2) using pin (3). Secure pin (3) with klik pins (4).
- STEP 2: Remove bucket from dipperstick and curl cylinder pin connections. The dipperstick pin will be used to attach the knuckle assembly to the dipperstick. The curl cylinder pin will not be required for drive unit installation.
- STEP 3: Space the two ear assemblies (5) to the width of the dipperstick and secure them to the knuckle sub-assembly (2) using u-bolts (6) and nuts (7). **The ear assemblies should be spaced evenly from the center of the knuckle sub-assembly and the safety signs should be facing out.** Nuts (7) must be torqued to 75 ft.-lbs. Nuts (7) should be checked and re-torqued after the first hour of use.
- STEP 4: Attach knuckle assembly/drive unit to the dipperstick using the dipperstick pin removed from the bucket in STEP 2. Secure the bucket pin per vehicle manufacturer's recommendations.

Assembly & Installation

TLB & Excavator Mount

Drive unit and auger exploded views and part lists are detailed on separate pages in this manual.

REF. NO.	PART NO.	DESCRIPTION	QTY.
1	----	Drive Unit	1
2	10247	Knuckle Sub-Assembly	1
3	10032	Pin (1-1/4" x 7-5/8")	1
4	1600	Klik Pin	2
5	----	Ear Assembly	2
6	10242	Tube-Clamp	2
7	10243	Bolt (5/8"-11 x 2")	4
8	3092	Nut (5/8"-11)	4
9	10038	Special Retaining Bolt - 2" Hex (3/4"-10 x 4", Gr. 8, 3/4" of thread)	1
	10039	Special Retaining Bolt - 2-9/16" Rd. (7/8"-9 x 4-1/4", Gr. 8, 3/4" of thread)	1
10	10041	Nut (3/4"-10) - 2" Hex	1
	10042	Nut (7/8"-9) - 2-9/16" Rd.	

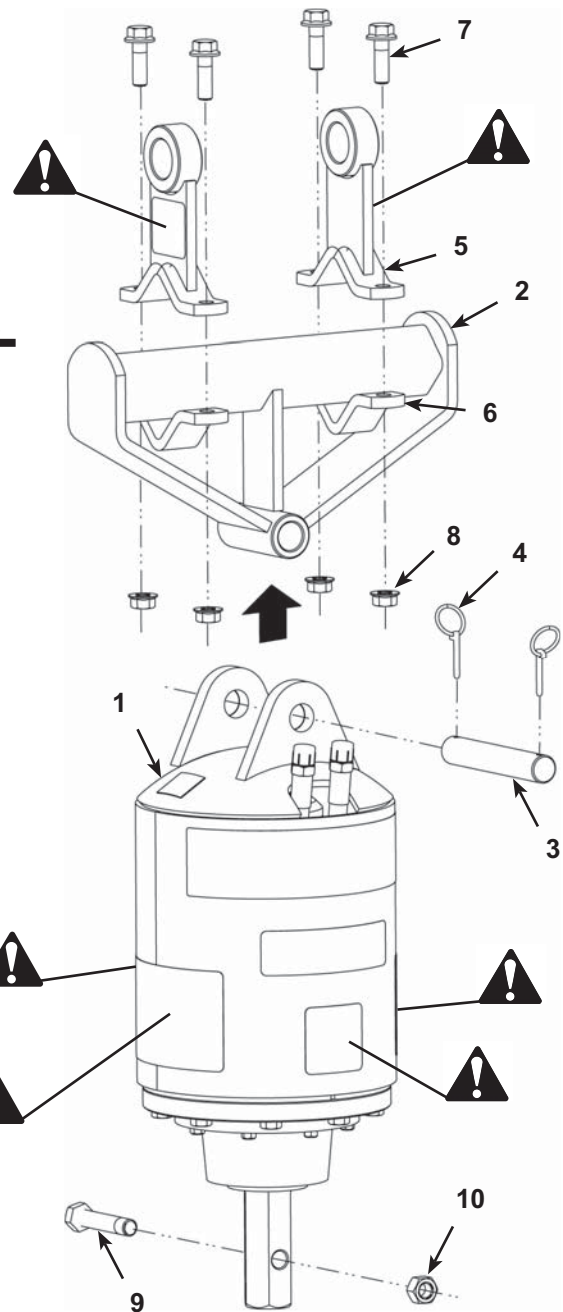

CAUTION

Because of the weight of some components, and because some components are difficult to balance, two people are required for safe assembly and installation of this equipment.

WARNING

Personal protection equipment including hard hat, safety glasses, safety shoes, and gloves are recommended during assembly, installation, operation, maintenance, removal, or movement of the earth auger. Do not allow long hair, loose fitting clothing, or jewelry to be around moving parts.

= Safety Sign Location

- STEP 1: Attach drive unit (1) to the knuckle sub-assembly (2) using pin (3). Secure pin (3) with klik pins (4).
- STEP 2: Remove bucket from dipperstick and curl cylinder pin connections. The dipperstick pin will be used to attach the knuckle assembly to the dipperstick. The curl cylinder pin will not be required for drive unit installation.
- STEP 3: Space the two ear assemblies (5) to the width of the dipperstick and secure them to the knuckle sub-assembly (2) using tube-clamps (6), bolts (7), and nuts (8). **The ear assemblies should be spaced evenly from the center of the knuckle sub-assembly and the safety signs should be facing out.** Nuts (8) must be torqued to 50 ft.-lbs. Nuts (8) should be checked and re-torqued after the first hour of use.
- STEP 4: Attach knuckle assembly/drive unit to the dipperstick using the dipperstick pin removed from the bucket in STEP 2. Secure the bucket pin per vehicle manufacturer's recommendations.

Assembly & Installation

Bolt-on Bucket Mount

Drive unit and auger exploded views and part lists are detailed on separate pages in this manual.

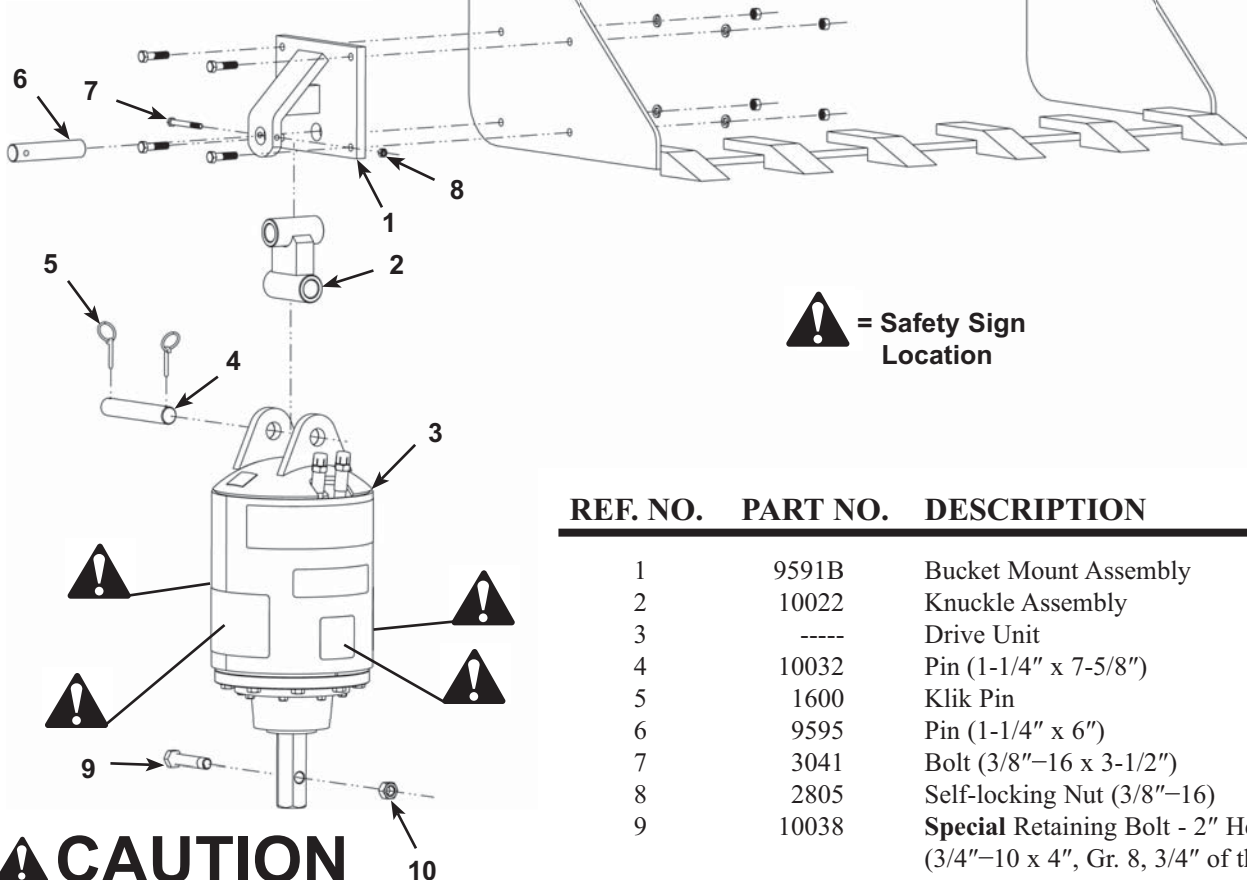

 = Safety Sign Location

REF. NO.	PART NO.	DESCRIPTION	QTY.
1	9591B	Bucket Mount Assembly	1
2	10022	Knuckle Assembly	1
3	----	Drive Unit	1
4	10032	Pin (1-1/4" x 7-5/8")	1
5	1600	Klik Pin	2
6	9595	Pin (1-1/4" x 6")	1
7	3041	Bolt (3/8"-16 x 3-1/2")	1
8	2805	Self-locking Nut (3/8"-16)	1
9	10038	Special Retaining Bolt - 2" Hex (3/4"-10 x 4", Gr. 8, 3/4" of thread)	1
	10039	Special Retaining Bolt - 2-9/16" Rd. (7/8"-9 x 4-1/4", Gr. 8, 3/4" of thread)	
10	10041	Nut (3/4"-10) - 2" Hex	1
	10042	Nut (7/8"-9) - 2-9/16" Rd.	

CAUTION

Because of the weight of some components, and because some components are difficult to balance, two people are required for safe assembly and installation of this equipment.

WARNING

Personal protection equipment including hard hat, safety glasses, safety shoes, and gloves are recommended during assembly, installation, operation, maintenance, removal, or movement of the earth auger. Do not allow long hair, loose fitting clothing, or jewelry to be around moving parts.

NOTE Consideration must be given to the installation location of bolt-on bucket mount kit. The drive unit should be able to swing during normal operation without interference from the bucket. The bucket must be constructed with sufficient strength to safely handle the load forces generated during drilling. Position drive unit to allow space for the hydraulic hose connections and routing of the hoses.

STEP 1: Drill four holes in the loader bucket to accommodate bucket mount assembly (1).

STEP 2: Bolt mount assembly to the left or right outside vertical surface of the bucket. (See figure above.) Hardware to attach the mount assembly is not included in the kit. You will need the following:

- 4 bolts (1/2" diameter, Grade 5 or greater)
- 4 lock washers (1/2")
- 4 nuts (1/2")

STEP 3: Attach knuckle assembly (2) to the drive unit (3) using pin (4). Secure pin (4) with klik pins (5).

STEP 4: Attach knuckle assembly/drive unit to mount assembly (1) using pin (6). Secure pin (6) with bolt (7) and nut (8).

Assembly & Installation

(continued)

STEP 5: Grease the inside of the auger collar liberally and attach the auger with the retaining bolt and nut that came attached to the drive unit spindle. This is a **special thread length** bolt - use genuine Danuser replacement parts only. For hex spindle, use Danuser PN 10038 (3/4"-10 x 4", Gr. 8, 3/4" of thread) **special** retaining bolt and nut PN 10041. NEVER use a bolt longer than 4". For round spindle, use Danuser PN 10039 (7/8"-9 x 4-1/4", Gr. 8, 3/4" of thread) **special** retaining bolt and nut PN 10042. NEVER use a bolt longer than 4-1/4".

NOTE

Each time an auger or extension is attached to the drive unit, the inside of the collar should be coated liberally with grease.

STEP 6: The hydraulic fittings on the top of the drive unit are #10 JIC male. Install 1/2" Danuser Hose Kit if your unit delivers less than 20 GPM. Install 3/4" Danuser Hose Kit if your unit delivers 20 GPM or more. Danuser Hose Kits include abrasion sleeves. Since the motor is reversible, hose connections to motor fittings are interchangeable.

NOTE

The hydraulic hoses should be equipped with a 45-degree fitting on the drive unit end.

NOTE

All hoses and fittings used to connect the earth auger should be thoroughly cleaned before use. Care should be taken to see that no thread sealer or metal chips are forced to the inside of the joints when connections are being tightened.

STEP 7: If you did not purchase quick couplers with your unit, you must obtain and install the proper hydraulic quick couplers for your particular vehicle.

NOTE

Fittings must be compatible with the fittings on your vehicle. Be sure the threads match on the hydraulic quick couplers you are using.

STEP 8: After you have tightened the drive unit connections, run the hoses through the hose holder on the quick attach plate and plug them into your auxiliary hydraulic outlets.

WARNING

Remember hydraulic systems are under pressure whenever the engine is running and may hold pressure after shutdown. Before connecting or disconnecting hydraulic hoses, be sure to relieve all pressure by cycling all hydraulic controls after shutdown.

STEP 9: Test the vehicle to make sure you have enough hose length to perform the full range of the loader arms' operating heights.

WARNING

Never check pressurized system for leaks with your bare hand. Wear proper hand and eye protection and use wood or cardboard when searching for suspected leaks. Oil escaping from pinhole leaks under pressure can penetrate skin and create a serious medical emergency. If any fluid is injected into the skin, gangrene, blood poisoning, even death may result. Obtain medical attention immediately.

Operation

WARNING

Serious injury or death can result from misuse of this equipment.

WARNING

Personal protection equipment including hard hat, safety glasses, safety shoes, and gloves are recommended during assembly, installation, operation, maintenance, removal, or movement of the earth auger. Do not allow long hair, loose fitting clothing, or jewelry to be around moving parts.

Read and understand this Operator's Manual carefully before attempting to operate the Danuser Earth Auger. You are responsible for furnishing this manual to others who may use the unit. If you have any questions regarding the proper assembly, installation, or operation of this earth auger, contact your dealer or Danuser LLC.

DANGER

Differences in diameter and length of auger when combined with various heights of loader arms can allow the auger to come into contact with skid-steer or operator when earth auger is outside of cradle.

Before operating, check clearances between skid-steer and auger, as well as operator and auger, across the full range of loader arms' operating heights.

Keep earth auger in cradle when not drilling.

DANGER

To reduce the risk of personal injury, never transport with the drive unit out of the cradle or while the auger is rotating.

DANGER

This earth auger was designed for one-man operation from the vehicle seat. It is the responsibility of the operator to see that bystanders and all other people are at least twenty-five feet (25') from the earth auger in operation or under power. Serious personal injury or death may result if any attempt is made to assist earth auger operation by hand.

STEP 1: Contact local utility companies to make certain there are no buried gas lines, electrical cables, etc., in the work area. Clear area of objects that could wrap around the auger or might be thrown. Check for ditches, stumps, holes, or other obstacles that could cause the vehicle to roll.

STEP 2: Lay out and mark where you want to drill your holes.

STEP 3: Lower the auger point slowly to the ground with the auger not powered.

NOTE Skid-steer mounted earth augers should not come in contact with the cradle during drilling maneuvers. Drill with the quick attach plate in the horizontal position.

STEP 4: With the auger point lowered to the ground and before engaging the auger, move the vehicle slowly left, right, forward, or backward as needed until the auger appears vertical to the ground.

STEP 5: Actuate the hydraulics to start the auger's rotation in the clockwise direction and increase the speed as required so dirt is conveyed from the hole.

NOTE The hydraulic actuation lever connected to the earth auger will have three positions: clockwise rotation, stop (neutral), and counter-clockwise rotation. The clockwise and counter-clockwise positions may be changed by switching the hose connections.

DANGER

Never position the auger point by hand or with any tool when the vehicle is running. Never position the auger point by putting your hands on the auger or the drive unit.

Operation

(continued)

DANGER

To prevent injury, keep an area of at least twenty-five feet (25') around the auger clear of bystanders and all other people.

DANGER

Do not shovel dirt away from a rotating auger, as the shovel can be caught and thrown by the auger.

WARNING

Replace a broken, damaged, or missing auger retaining bolt **ONLY** with an authorized factory replacement. An auger retaining bolt that is too long increases the possibility of personal injury. The auger retaining bolt must be of the proper size and grade to function properly.

STEP 6: The hydraulic flow rate or pressure should not exceed the earth auger's specified maximums. The hydraulic minimums must be met to deliver satisfactory performance. Use only enough down pressure to assure positive penetration of the auger into the ground. Ease up on down pressure if auger rotation slows down drastically or stalls. Excessive down pressure will cause the auger to frequently stall. See Hydraulic Requirements section for filtration, pressure, and flow rate specifications.

NOTE

If you have difficulty penetrating hard ground, refer to the Troubleshooting section.

STEP 7: When the auger has been lowered about 24 inches into the ground, raise the auger almost out of the hole to clear the dirt, then drill deeper and raise the auger again. Repeat this procedure until the desired hole depth is reached.

NOTE

The earth auger should be raised and lowered by changing the elevation and not the tilt of the quick attach plate.

STEP 8: When the auger has reached the full depth required, allow the auger to dwell momentarily at this depth at a slower speed to assist in cleaning out the hole.

STEP 9: Deactivate the earth auger, and raise it from the hole.

NOTE

For "heavy" soil conditions, allow the auger to turn at slow speed while raising it to the top of the hole.

STEP 10: Move away from the hole, then remove loose dirt from the auger by momentarily actuating the earth auger and spinning it at a faster speed than used for drilling.

STEP 11: If necessary, repeat STEPS 8 and 9 to obtain a cleaner hole.

NOTE

In some soil conditions, or when excessive down pressure is applied, the auger may screw itself into the ground and become stuck, causing the earth auger to stall. Do not attempt to pull the auger out of the ground. Instead, reverse the auger rotation (counter-clockwise), and slowly raise the auger. Once unstuck, continue operation.

NOTE

If the auger becomes lodged under rocks, roots, or other large obstructions, do not attempt to pull the auger out of the ground. If this happens, reverse the auger rotation (counter-clockwise), and slowly raise the auger. Once unstuck, continue operation.

NOTE

Since the earth auger uses a Grade 8 retaining bolt, all vehicles must be protected with relief valves or some other means of protection against excessive pressures. Failure of the retaining bolt is a possible indication of excessive pressure.

Replacement of the retaining bolt should be as follows:

- Shut off the vehicle engine, and remove the vehicle key.
- Install a new Danuser retaining bolt. This is a **special thread length** bolt - use genuine Danuser replacement parts only. For hex spindle, use Danuser PN 10038 (3/4"-10 x 4", Gr. 8, 3/4" of thread) **special** retaining bolt and nut PN 10041. NEVER use a bolt longer than 4". For round spindle, use Danuser PN 10039 (7/8"-9 x 4-1/4", Gr. 8, 3/4" of thread) **special** retaining bolt and nut PN 10042. NEVER use a bolt longer than 4-1/4".
- Tighten the retaining bolt and nut securely.

STEP 12: Deactivate the auger and place the drive unit in the cradle when moving between holes.

NOTE

Frequently check the condition of the auger teeth and point, and replace them when wear is detected. Always keep spare parts on hand for replacements to avoid damage to the auger head and auger flighting.

Troubleshooting

PROBLEM	POSSIBLE CAUSE	SOLUTION
Slow Speed	<ul style="list-style-type: none"> a) Low flow b) Fittings or connections are too small or incompatible c) Line restrictions d) Dirty oil or oil filter e) Hydraulic pump worn or damaged 	<p>Check with flow meter. If low, investigate the cause.</p> <p>Replace with proper fittings.</p> <p>Clear lines.</p> <p>Change oil and oil filter according to vehicle manufacturer's recommendation.</p> <p>See your dealer for repairs.</p>
Auger Will Not Drill	<ul style="list-style-type: none"> a) Worn teeth or point b) Ground too hard and dry 	<p>Replace with new ones.</p> <p>Order hardfaced or carbide teeth and point.</p>
Lacks Drilling Power	<ul style="list-style-type: none"> a) Low system pressure (PSI) 	<p>Check with pressure gauge. If low, investigate the cause.</p>
Oil Leaks	<ul style="list-style-type: none"> a) Fittings loose or damaged b) Hoses loose or damaged c) Hydraulic motor seals worn or damaged 	<p>Tighten or replace fittings.</p> <p>Tighten or replace hoses.</p> <p>See your dealer for repairs.</p>
Oil Over Heating	<ul style="list-style-type: none"> a) Low quantity of hydraulic oil b) Improper oil c) Dirty oil or oil filter d) Fittings loose or damaged e) Hoses loose or damaged f) Improper hose size 	<p>Fill reservoir to proper level. Increase reservoir storage capacity.</p> <p>Replace with proper oil.</p> <p>Change oil and oil filter according to vehicle manufacturer's recommendation.</p> <p>Tighten or replace fittings.</p> <p>Tighten or replace hoses.</p> <p>Check hose diameter and length requirements.</p>
Hydraulic Hose Failure	<ul style="list-style-type: none"> a) Hydraulic relief pressure setting too high b) Hoses worn or damaged c) Hose rating too low for hydraulic system pressure d) Hoses pinched 	<p>Adjust vehicle hydraulic relief pressure setting to within drive unit specifications.</p> <p>Replace hoses.</p> <p>Replace with hoses with working pressure rated higher than vehicle hydraulic pressure.</p> <p>Reroute hoses.</p>

For additional assistance, please call your dealer or contact Danuser direct:

Tel: (573) 642-2246

Fax: (573) 642-2240

E-mail: sales@danuser.com

DAILY

CHECK PLANETARY GEAR OIL LEVEL

Check oil level daily to assure proper lubrication is maintained. Check by removing the fill plug - with the drive unit standing vertically. Oil should just cover the visible gear.

CHECK FOR CLEAN HYDRAULIC OIL

The majority of all hydraulic component failures are caused by contamination of the hydraulic oil. At all times, keep dirt and other contaminants from entering the hydraulic system during connecting and disconnecting the hydraulic system. Always use dust caps and plugs on all quick disconnects when not in use.

CHECK ALL HYDRAULIC HOSE ASSEMBLIES

Check for cracked or brittle hoses. Replace hoses immediately if cracked or brittle. Replacement of hoses before failure will prevent loss of hydraulic oil, hydraulic oil contamination, and component damage caused by cavitation.

CHECK DRIVE UNIT AND ALL ACCESSORIES

Check for loose, bent, cracked, or worn bolts and fasteners. Check drive unit output spindle for bends, cracks, breaks, or wear. Replace the bolts, fasteners, or output spindle if any of these conditions exist.

CHECK AUGER

Check for loose or worn cutting teeth and point. Worn teeth or point can dramatically affect auger penetration and greatly reduce the life of the auger. Always keep spare teeth and points on hand. Liberally coat the auger with grease once the paint is removed to prevent rusting.

CHECK ALL CONNECTING PINS

Check for bends, cracks, breaks, or wear. Replace if any of these conditions exist.

EACH TIME AN AUGER OR EXTENSION IS ATTACHED

COAT THE INSIDE DIAMETER OF THE AUGER OR EXTENSION COLLAR

To prevent rust and reduce wear, liberally coat with grease the inside diameter of the auger and extension collars each time they are attached.

AFTER 1ST 50 HOURS, THEN EVERY 1000 HOURS OR YEARLY

CHANGE OIL

Change planetary gear reduction oil after first 50 hours of operation, then every 1000 hours or 12 months, whichever comes first. Use heavy duty extreme pressure lubricant API-GL-5 85W-140 for filling the planetary gear reduction. Approximate oil capacity is two pints (.95 liters).

Drive Unit Parts

 = Safety Sign Location

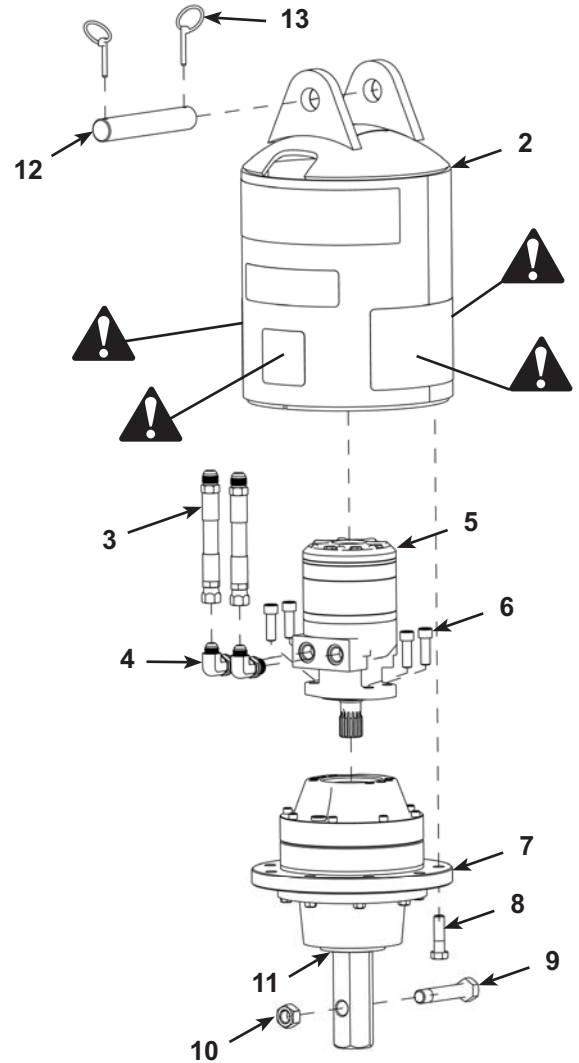

REF. NO.	PART NO.	DESCRIPTION	QTY.	MODELS
1	10061 (R), 10062 (H)	Drive Unit	1	615 Hex or Rd.
	10010 (R), 10011 (H)	Drive Unit	1	1025 Hex or Rd.
	10015 (R), 10016 (H)	Drive Unit	1	1530 Hex or Rd.
	10020 (R), 10021 (H)	Drive Unit	1	2035 Hex or Rd.
2	10969	Housing Assembly	1	615, 1025, 1530, 2035
3	21244	Hose Assembly	2	615, 1025, 1530, 2035
4	20034	90 Degree Elbow	2	615, 1025, 1530, 2035
5	10961	Hydraulic Motor	1	615
	10962	Hydraulic Motor	1	1025
	10963	Hydraulic Motor	1	1530
	10964	Hydraulic Motor	1	2035
6	6156	Socket Head Bolt (1/2"-13 x 1-1/2")	4	615, 1025, 1530, 2035
7	10052	Planetary Gear Reduction	1	615, 1025, 1530, 2035 Hex
	10053	Planetary Gear Reduction	1	615, 1025, 1530, 2035 Rd.
8	10036	Bolt (9/16"-12 x 2", Gr. 5)	9	615, 1025, 1530, 2035
9	10038	Special Retaining Bolt (3/4"-10 x 4", Gr. 8, 3/4" of thread)	1	615, 1025, 1530, 2035 Hex
	10039	Special Retaining Bolt (7/8"-9 x 4-1/4", Gr. 8, 3/4" of thread)	1	615, 1025, 1530, 2035 Rd.
10	10041	Nut (3/4"-10)	1	615, 1025, 1530, 2035 Hex
	10042	Nut (7/8"-9)	1	615, 1025, 1530, 2035 Rd.
11	9871	Output Seal	1	615, 1025, 1530, 2035
12	10032	Pin (1-1/4" x 7-5/8")	1	615, 1025, 1530, 2035
13	1600	Klik Pin	2	615, 1025, 1530, 2035

Decals & Safety Signs



PART NO. DANUSER101

Locations: Quick Attach Plate, sides
Drive Unit, front

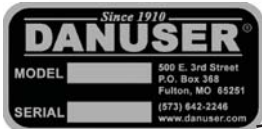

Model No. & Serial No.

Location: Drive Unit, top



PART NO. 9875

Location: Drive Unit, top



PART NO. DIG4

Location: Drive Unit, back



PART NO. DIG8

Location: Auger



PART NO. DIG5

Location: Drive Unit, front

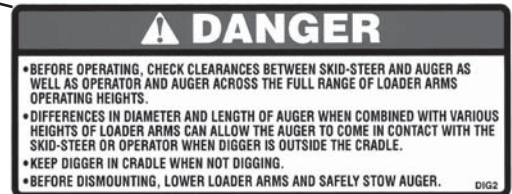

PART NO. DIG2

Location: Quick Attach Plate, top

1025

PART NO. 10984 (615)

PART NO. 10985 (1025)

PART NO. 10986 (1530)

PART NO. 10987 (2035)

Location: Drive Unit, front



PART NO. DIG3

Locations: Drive Unit, sides



Clean or replace all safety signs if they cannot be clearly read and understood.

Decals & Safety Signs

(continued)

⚠️ WARNING

Clean or replace all safety signs if they cannot be clearly read and understood.



PART NO. DIG6
Location: Knuckle Ears, sides

MINI-EXCAVATOR KNUCKLE



PART NO. DIG7
Location: Knuckle Ears, sides

TLB & EXCAVATOR KNUCKLE



PART NO. DIG27
Location: Quick Attach Plate, top

SKID-STEER OFFSET MOUNT

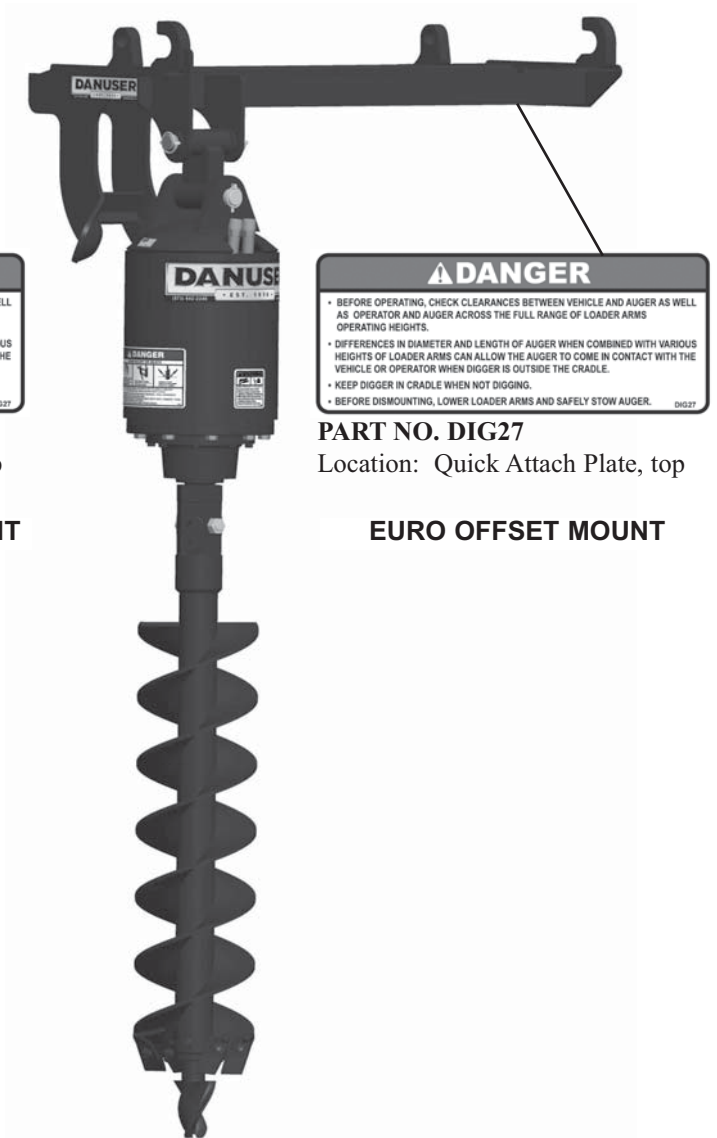

PART NO. DIG27
Location: Quick Attach Plate, top

EURO OFFSET MOUNT

Augers & Accessories

 = Safety Sign Location

AUGER COLLAR

DESC.	PART NO.
2" Hex	10328
2-9/16" Rd.	10329

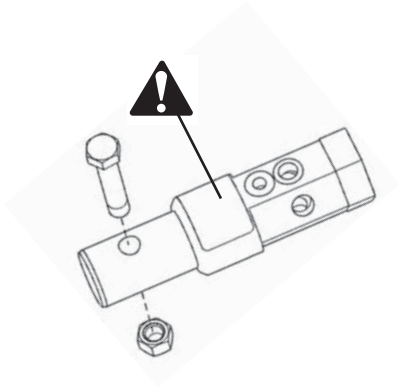
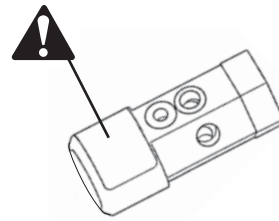

AUGER ADAPTERS

DRIVE UNIT		AUGER COLLAR	PART NO.
2" Hex	to	2-9/16" Rd.	10921
2" Hex	to	2" Rd.	10922
2-9/16" Rd.	to	2" Hex	10923
2-9/16" Rd.	to	2" Rd.	10924

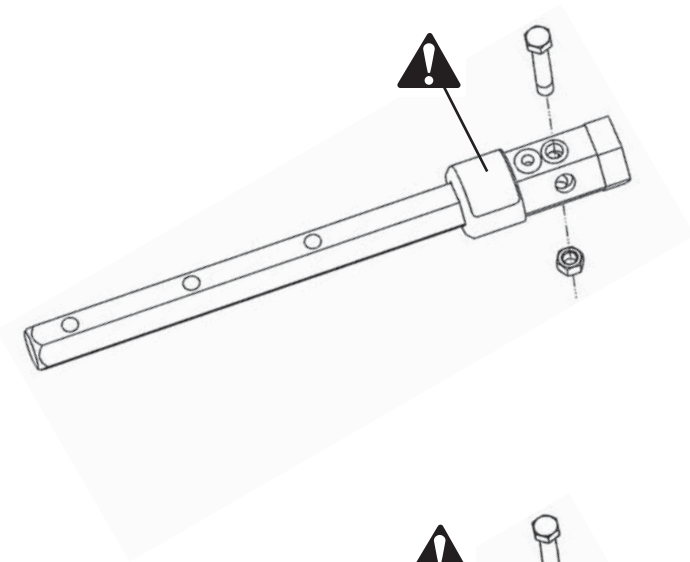

VARIABLE LENGTH EXTENSIONS

LENGTH	2" HEX	2-9/16" RD.
12"	----	10903
24"	10900	10904
48"	10901	10905
72"	10902	10906

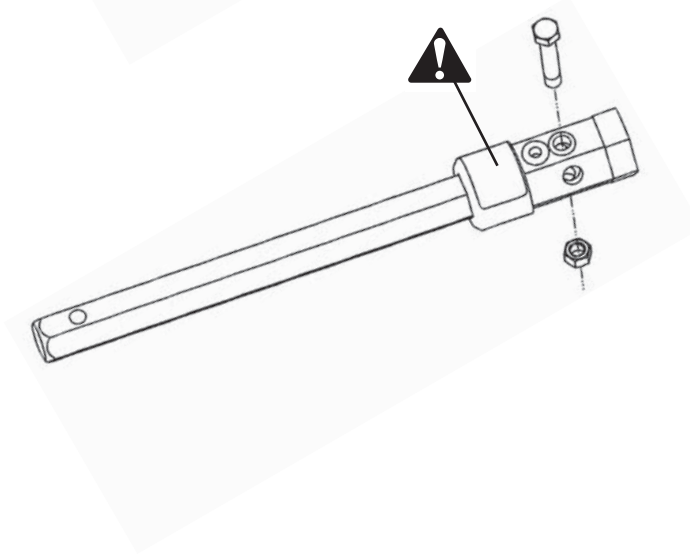

FIXED LENGTH EXTENSIONS

LENGTH	2" HEX	2-9/16" RD.
12"	10910	10914
24"	10911	10915
48"	10912	10916
72"	10913	10917

Augers & Accessories

(continued)

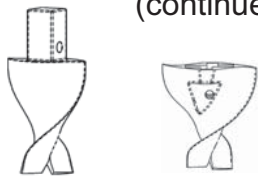

FISHTAIL POINT	
Dirt	10331
Hardfaced	10332
Chunky Carbide	10335
Nut	10412
Bolt	10413
4" diameter auger below	
Dirt	10333
Hardfaced	10334
Chunky Carbide	10336
Nut	10412
Bolt	10416

TEETH BOLT & NUT	
Carriage Bolt	10410
Nut	10411



GAGE TOOTH	
Dirt	10340
Hardfaced	10341



WISDOM TOOTH	
Dirt	10337
Hardfaced	10338
Carbide	10339



CHISEL TOOTH	
Dirt	10342
Hardfaced	10343
Carbide	10344

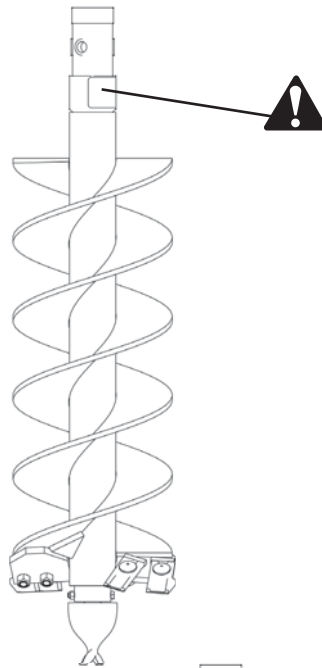

"FAB" AUGERS - 4' LENGTH			
DIA.	NO. OF TEETH	2" HEX	2-9/16" RD.
4"	0	10600	10601
6"	2	10603	10604
8"	2	10606	10607
9"	3	10609	10610
10"	3	10612	10613
12"	4	10615	10616
15"	5	10618	10619
16"	5	10621	10622
18"	6	10624	10625
20"	6	10627	10628
24"	8	10630	10631
30"	9	10633	10634
36"	11	10636	10637

Please call Danuser for 3', 5', or 6' requests.

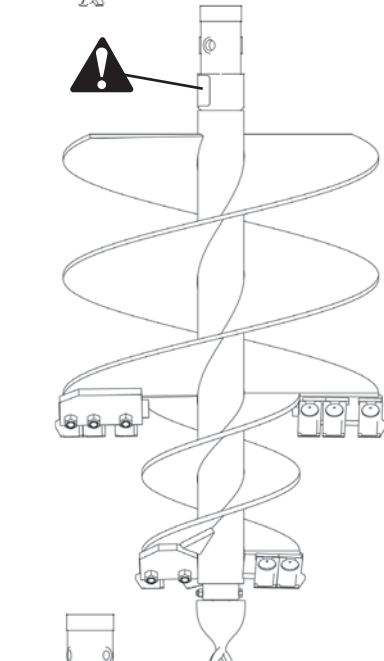

"TREE" AUGERS - 4' LENGTH			
DIA.	NO. OF TEETH	2" HEX	2-9/16" RD.
18"-9"	7	10639	10640
24"-12"	10	10642	10643
30"-15"	11	10645	10646
36"-18"	13	10648	10649

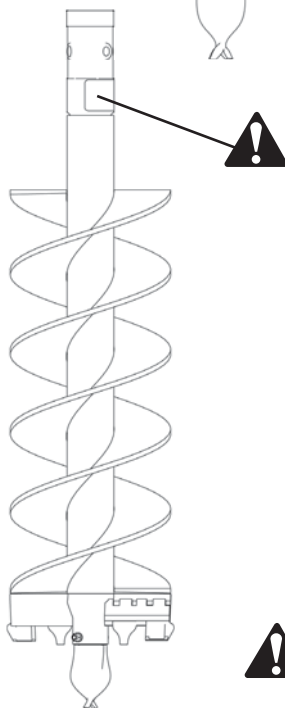

"CAST" AUGERS - 4' LENGTH			
DIA.	NO. OF TEETH	2" HEX	2-9/16" RD.
6"	2	10657	10658
8"	4	10660	10661
9"	4	10663	10664
10"	4	10666	10667
12"	4	10669	10670
15"	6	10672	10673
16"	6	10675	10676
18"	6	10678	10679
20"	6	10681	10682
24"	8	10684	10685
30"	10	10687	10688
36"	12	10690	10691

Please call Danuser for 3', 5', or 6' requests.

= Safety Sign Location

Augers & Accessories

(continued)

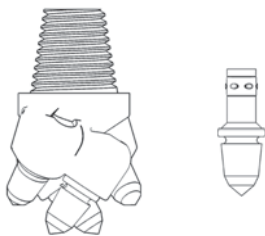

"BULLET" ROCK	
Pilot	10758
Tooth	10759
Tooth Holder	10760

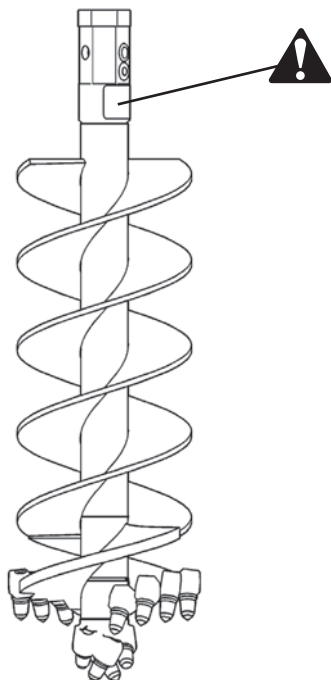

"BULLET" ROCK AUGERS 4' LENGTH

DIA.	NO. OF TEETH	2" HEX	2-9/16" RD.
4.5"	4	10700	10701
6"	6	10703	10704
7"	8	10706	10707
8"	8	10709	10710
9"	8	10712	10713
10"	10	10715	10716
12"	12	10718	10719
15"	15	10740	10741
18"	18	10727	10728
24"	22	10730	10731
30"	24	10733	10734
36"	30	10736	10737

 = Safety Sign Location

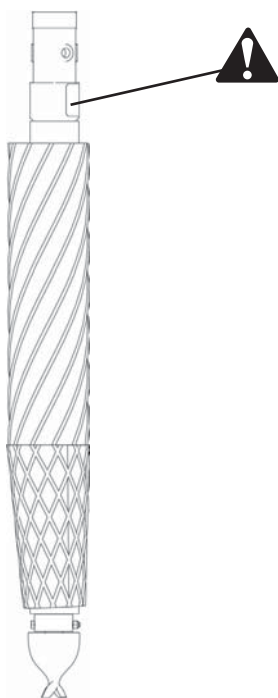

WOBBLE AUGERS - 4' LENGTH

DIA.	NO. OF TEETH	2" HEX	2-9/16" RD.
4"	N/A	20600	20601
6"	N/A	20603	20604
9"	N/A	20606	20607

The Wobble Auger pushes through dirt, sand, clay, asphalt, compacted rock, and embedded rock. The 9" Wobble Auger should be used on a skid-steer with an Operating Load or Rated Operating Capacity of 2250 lbs. or greater, utilizing an auger drive with 2000 ft. lbs. of torque or greater.

See patent at danuser.com/patents.

HOSE KITS & COUPLERS

1/2" Hose Kit with flat face couplers	10050
3/4" Hose Kit with flat face couplers	10051
1/2" Hose Kit (includes fittings NOT couplers)	10043
3/4" Hose Kit (includes fittings NOT couplers)	10044
Male Hydraulic Coupler	10048
Female Hydraulic Coupler	10049

FLAT FACE ISO COUPLERS

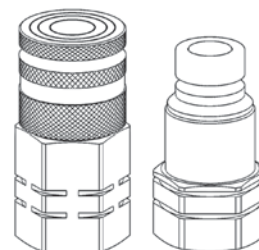

This page is intentionally blank.

Warranty

DANUSER

Model # _____

LIMITED WARRANTY

Serial # _____

Danuser LLC (“Danuser”) warrants its products, under normal use and maintenance, to be free from defects in material and workmanship for periods specified below from the purchase date from an authorized Danuser Dealer. Start of the warranty period is determined by purchase date given on your returned WARRANTY REGISTRATION FORM. Proof of purchase may be required. This Limited Warranty is extended only to the original purchaser of Danuser products.

Drive Units - 5 Years

Mountings - 1 Year

Augers - 1 Year

1. During the applicable warranty period, Danuser, at its option, will repair or replace any part determined by Danuser to be defective. Such repair or replacement shall take place at Danuser’s factory or a location designated by Danuser. Under no circumstances shall Danuser be obligated for the cost of any repair or replacement by anyone other than Danuser without its express written consent.
2. Parts may not be returned without written authorization from Danuser.
3. Some purchased components, including but not limited to hydraulic motors, planetary gears, and augers, are subject to the inspection and warranty of the respective manufacturer. Thus, delays in a warranty determination can be expected while Danuser awaits their decision.
4. This warranty is void if any attempt is made to make field repairs to hydraulic motors or planetary gears. To qualify for warranty inspection, the complete drive unit must be returned in its original “failed” condition.
5. To make a claim under this warranty, first contact your authorized Danuser Dealer. The Danuser Dealer shall complete the Warranty Claim Form and obtain written authorization from Danuser to return parts. All warranty claims must include detailed information regarding make and model of vehicle on which the Danuser product was mounted, hours of use, description of events that led up to the failure, and any other information helpful in reviewing the warranty claim. All warranty returns must be prepaid. Shipments arriving at our factory on a freight collect basis will be refused by our receiving department. The freight charge will be credited if the parts are determined by Danuser to be defective, and the associated freight costs in returning those parts will be prepaid by Danuser. NOTE: Hydraulic motors must arrive with all ports sealed from dirt and moisture. If a motor arrives with open ports, the warranty is void and no inspection will be made.
6. Products or parts thereof which, as determined by Danuser’s examination, show wear from normal use, have been improperly operated, damaged by accident or negligence, field repaired, altered or modified are not considered defective in material and workmanship and are not covered by this warranty. This warranty does not apply to parts subject to normal wear, such as auger teeth and points, or to damage caused by the failure to perform recommended maintenance or to replace worn parts. This warranty shall not obligate Danuser to bear any cost of labor for field repair, replacement, testing, or adjustment nor for damage caused by accident, abuse, misuse, or environmental elements.
7. Any parts or labor required to repair or replace parts not covered under this warranty will be charged to the customer. Parts repaired or replaced by Danuser are then covered by this warranty only for the remainder of the original warranty as if such parts were original parts.
8. Danuser reserves the right to change its specifications and designs at any time.

This warranty is exclusive and in lieu of all other express warranties, if any, including the implied warranties of merchantability and fitness for a particular purpose. It shall not extend beyond the duration of the expressed warranty provided herein and the remedy for violations of any implied warranty shall be limited to repair or replacement of the defective part pursuant to the terms contained herein. No employee, dealer, salesman, or representative is authorized to change this warranty in any way or grant any other warranty. Danuser shall not be liable for any consequential, incidental, or punitive damages, losses, or expenses, including those resulting from or caused by any defects.

Danuser LLC
500 E. 3rd St.
P.O. Box 368
Fulton, MO 65251

Tel: (573) 642-2246
Fax: (573) 642-2240
E-mail: sales@danuser.com
Website: www.danuser.com